

**EXACT SOLUTIONS OF EQUATIONS OF ROTATIONALLY SYMMETRIC
MOTION OF AN IDEAL INCOMPRESSIBLE LIQUID**

E. Yu. Meshcheryakova

UDC 532.511+517.9

A partially invariant solution of the Euler equations is considered, where the vertical component of velocity is a function of the vertical coordinate and time, whereas the remaining components of velocity and pressure are independent of the polar angle in a cylindrical coordinate system. Using the classification of equations obtained by analysis of an overdetermined system, we consider two hyperbolic systems: the first one describes the motion of a cylindrical layer of an ideal incompressible liquid under a punch, and the second system allows obtaining solutions in a half-cylinder with singularities at the axis of symmetry. A class of new exact solutions is obtained, which describe vortex motion of an ideal incompressible liquid, including the motion with singularities (sources of vortices) located along the axis of symmetry.

1. New Class of Exact Solutions. We consider a system of the Euler equations that describe the motion of an ideal incompressible liquid:

$$\mathbf{v}_t + \mathbf{v} \cdot \nabla \mathbf{v} + \nabla p = 0, \quad \nabla \mathbf{v} = 0. \tag{1.1}$$

Here \mathbf{v} is the velocity vector, p is the pressure, t is the time, and ∇ is the gradient with respect to spatial variables $x_1, x_2,$ and x_3 . Without loss of generality, the density of the liquid is assumed to be equal to unity.

The group properties of system (1.1) were studied in [1]. This system admits an infinite-dimensional Lie group PG generated by the operators

$$\begin{aligned} Z_1 &= t \frac{\partial}{\partial t} + \sum_{i=1}^3 x_i \frac{\partial}{\partial x_i}, \quad Z_2 = -t \frac{\partial}{\partial t} + \sum_{i=1}^3 v_i \frac{\partial}{\partial v_i} + 2p \frac{\partial}{\partial p}, \\ X_{kl} &= x_l \frac{\partial}{\partial x_k} - x_k \frac{\partial}{\partial x_l} + v_l \frac{\partial}{\partial v_k} - v_k \frac{\partial}{\partial v_l} \quad (k = 1, 2, 3; l = 1, 2; l < k), \quad X_0 = \frac{\partial}{\partial t}, \\ \Phi &= \varphi(t) \frac{\partial}{\partial p}, \quad \Psi_k = \psi_k(t) \frac{\partial}{\partial x_k} + \dot{\psi}_k(t) \frac{\partial}{\partial v_k} - x_k \ddot{\psi}_k(t) \frac{\partial}{\partial p} \quad (k = 1, 2, 3). \end{aligned} \tag{1.2}$$

Many invariant solutions corresponding to the group PG have been studied. A partially invariant solution for (1.1) was obtained in [2]. Another example of a partially invariant solution can be found in [3]. The present work is based on the results of [3], which are briefly described below.

Pukhnachov [3] considered a partially invariant solution of the Euler equations generated by a six-parameter Lie group $G_6 \subset PG$ admitted by system (1.1). The group G_6 was chosen as follows. For $\psi_k = 1$ and $\psi_k = t$, system (1.2) yields the operators $X_k = \partial/\partial x_k$ and $Y_k = t \partial/\partial x_k + \partial/\partial v_k$, respectively. The chosen group $G_6 \subset PG$ is generated by the operators $X_1, X_2, Y_1, Y_2, X_{12}$, and $P = \partial/\partial p$. Invariants of this group are $x_3, t,$ and v_3 . In this case, it is impossible to construct an invariant solution, since the necessary conditions for its existence are not fulfilled. For constructing a partially invariant solution, system (1.1) is written in cylindrical coordinates $\{r, \theta, z\}$. The projections of the velocity vector \mathbf{v} onto the corresponding axes are denoted as $u, v,$ and w . According to the

Lavrent'ev Institute of Hydrodynamics, Siberian Division, Russian Academy of Sciences, Novosibirsk 630090. Translated from *Prikladnaya Mekhanika i Tekhnicheskaya Fizika*, Vol. 43, No. 3, pp. 66–75, May–June, 2002. Original article submitted December 24, 2001.

universal algorithm of constructing partially invariant solutions (see [4]), the vertical component of velocity w is a function of two variables: the vertical coordinate z and time t , whereas two remaining components of velocity u and v and pressure p are independent of the polar angle θ :

$$w = w(z, t), \quad u = u(r, z, t), \quad v = v(r, z, t), \quad p = p(r, z, t). \quad (1.3)$$

Any partially invariant solution is characterized by a rank and a defect. In our case, the rank (number of independent invariant variables) is 2, and the defect (number of sought functions that cannot be represented via the invariants) is 3.

Substituting (1.3) into system (1.1) written in cylindrical coordinates, we obtain the system

$$\begin{aligned} u_t + uu_r + wu_z - r^{-1}v^2 + p_r &= 0, & v_t + uv_r + wv_z + r^{-1}uv &= 0, \\ w_t + ww_z + p_z &= 0, & u_r + r^{-1}u + w_z &= 0. \end{aligned} \quad (1.4)$$

After integration ($w_z = 0$), the last equation readily yields the function

$$u = -rw_z/2 + q/r, \quad (1.5)$$

where $q(z, t)$ is a new unknown function.

An analysis of the overdetermined system also yields the equation

$$r^2(a_t + wa_z - 2w_za) + r^2s_t - r^2w_z(rs_r + 4s)/2 + b_t + wb_z - wzb + 4qa + q(rs_r + 4s) = 0. \quad (1.6)$$

Here

$$a = -w_{zt}/2 - ww_{zz}/2 + w_z^2/4, \quad b = q_t + wq_z, \quad (1.7)$$

and the function $s(r, t)$ has to be determined. The functions w , q , and s being found, the pressure p is calculated by the formula

$$p = -\frac{1}{2}w^2 - \int_0^z w_t(\zeta, t) d\zeta + \int_{r_0}^r \rho s(\rho, t) d\rho + \varkappa(t),$$

where r_0 is a constant and $\varkappa(t)$ is an arbitrary function of time. The resultant overdetermined system also yields the velocity component v :

$$v = r^{-1}[r^4(a + s) + r^2b - q^2]^{1/2}. \quad (1.8)$$

In analyzing relation (1.6), one has also to distinguish the cases $w_{zz} \neq 0$ and $w_{zz} = 0$. For $w_{zz} = 0$, we may assume that $w = \lambda(t)z$ (without loss of generality, we assume that the additive function of time is equal to zero due to the invariance of the system with respect to the operator Ψ_3). For $w = \lambda(t)z$, the function a depends only on time: $a = -\dot{\lambda}/2 + \lambda^2/4$, and Eq. (1.6) acquires the form

$$r^2(\dot{a} - 2\lambda a) + r^2s_t - r^2\lambda(rs_r + 4s)/2 + b_t + \lambda zb_z - \lambda b + q(rs_r + 4s + 4a) = 0. \quad (1.9)$$

Then, we again have to consider two cases: $q_z = 0$ and $q_z \neq 0$. For $q_z = 0$, we obtain an equation that gives rather simple equations for the functions u and w and an equation for the function $s(r, t)$:

$$r^2s_t + (q - r^2\lambda/2)(rs_r + 4s) + r^2(\dot{a} - 2\lambda a) + \ddot{q} - \lambda\dot{q} + 4aq = 0.$$

Here $\lambda(t)$ and $q(t)$ are arbitrary functions of time and $a(t)$ is determined by formula (1.7). Nevertheless, for the case

$$\lambda = k/(1 + kt), \quad (1.10)$$

where $k = \text{const}$, the conditions on the free surface are satisfied; therefore, this case is considered separately in Sec. 4, where solutions for the problem of motion of a liquid under a punch are obtained.

For $q_z \neq 0$, Eq. (1.9) yields a simple expression

$$s = \chi(t) + Kr^{-4}, \quad (1.11)$$

where $\chi(t)$ is an arbitrary function of time and $K = \text{const}$. In this case, however, exact solutions have a more complicated form. With accuracy to the Andreev-Rodionov transform retaining system (1.4) (see [5]) $u' = u$, $v'^2 = v^2 - 2c/r^2$, $w' = w$, and $p' = p + c/r^2$, for $c = K/2$, we may assume that $K = 0$.

The most complicated field of velocities is obtained in the general case $w_{zz} \neq 0$. To study this case, we reduce the nonlinear factor-system

$$a_t + wa_z - 2aw_z - 2\chi w_z + \dot{\chi} = 0, \quad b_t + wb_z - w_z b + 4q(a + \chi) = 0$$

[a and b are determined by formulas (1.7) and $\dot{\chi} = d\chi/dt$] to ordinary differential equations by passing to the Lagrangian coordinates ζ and t . The function w being specified, the relationship between ζ and z is established on the basis of the solution of the Cauchy problem

$$\frac{dz}{dt} = w(z, t), \quad z = \zeta \quad \text{for } t = 0. \quad (1.12)$$

The new unknown functions are determined by the formulas

$$F(\zeta, t) = -w_z/2, \quad A(\zeta, t) = a, \quad Q(\zeta, t) = q, \quad B(\zeta, t) = b,$$

where the argument $z(\zeta, t)$ of the functions w_z , a , q , and b is the solution of problem (1.12). As a result, we obtain two systems, and the second system can be solved if the solution of the first one is known:

$$F_t + F^2 - A = 0, \quad A_t + 4F(A + \chi) + \dot{\chi} = 0; \quad (1.13)$$

$$Q_t - B = 0, \quad B_t + 2FB + 4(A + \chi)Q = 0. \quad (1.14)$$

The Cauchy problem is posed for systems of ordinary differential equations (1.13) and (1.14):

$$F = F_0(\zeta), \quad A = A_0(\zeta) \quad \text{for } t = 0; \quad (1.15)$$

$$Q = Q_0(\zeta), \quad B = B_0(\zeta) \quad \text{for } t = 0. \quad (1.16)$$

Solving (1.13)–(1.16), we obtain a wide class of new exact solutions of the Euler equations, which describe the vortex motion of an ideal incompressible liquid, including the motion with singularities.

We have also to consider the particular case $v = 0$. In this case, instead of Eq. (1.6), we obtain

$$r^2 a + r^2 s + b - q^2/r^2 = 0. \quad (1.17)$$

Since the function s is independent of z , it follows from (1.17) that $q = q(t)$ and $a = -\chi(t)$, whence we obtain the expression $s = \chi - \dot{q}/r^2 + q^2/r^4$. In this case, Eq. (1.17) reduces to the Riccati equation. Note, though this case describes the motion without swirl ($v = 0$), we can add swirl using the Andreev–Rodionov transform (see [5]): $v' = c/r$, where c is a constant.

2. Linearization. We briefly describe the results obtained in [6]. We consider system (1.13) and show that it can be linearized. First of all, we note that the function $A + \chi$ for an arbitrary value of ζ has a fixed sign. Assuming that $A + \chi \leq 0$, we introduce a new function $A + \chi = -G^2$ and write (1.13) in the form

$$F_t + F^2 + G^2 + \chi = 0, \quad G_t + 2FG = 0.$$

It is clear that the functions $F + G = C$ and $F - G = D$ satisfy the Riccati equations

$$C_t + C^2 + \chi = 0, \quad D_t + D^2 + \chi = 0. \quad (2.1)$$

After the substitution $C = \rho_t/\rho$ and $D = \sigma_t/\sigma$, Eqs. (2.1) reduce to the following linear equations:

$$\rho_{tt} + \chi\rho = 0, \quad \sigma_{tt} + \chi\sigma = 0. \quad (2.2)$$

Assuming that

$$\rho = 1, \quad \rho_t = F_0(\zeta) + G_0(\zeta), \quad \sigma = 1, \quad \sigma_t = F_0(\zeta) - G_0(\zeta) \quad \text{for } t = 0, \quad (2.3)$$

the initial data (1.15) are satisfied; here $G_0 = [-(A_0 + \chi_0)]^{1/2}$ and $\chi_0 = \chi(0)$.

Let $A + \chi \geq 0$. In this case, after the substitution $A + \chi = G^2$, system (1.13) reduces to the form

$$F_t + F^2 - G^2 + \chi = 0, \quad G_t + 2FG = 0. \quad (2.4)$$

It follows from (2.4) that the complex-valued function $F + iG = H$ satisfies the Riccati equation $H_t + H^2 + \chi = 0$, which after the substitution

$$H = \mu_t/\mu \quad (2.5)$$

reduces to the linear equation

$$\mu_{tt} + \chi\mu = 0. \quad (2.6)$$

The initial data for (2.6), by virtue of (1.15), have the form

$$\mu = 1, \quad \mu_t = F_0(\zeta) + iG_0(\zeta) \quad \text{for } t = 0, \quad (2.7)$$

where $G_0 = (A_0 + \chi_0)^{1/2}$.

If the function $F(\zeta, t)$ is found, then the function $w(z, t)$ is determined by the relations (see [3, 6])

$$z = \int_0^\zeta \exp\left(-2 \int_0^t F(\eta, \tau) d\tau\right) d\eta + z_0(t), \quad (2.8)$$

$$w = -2 \int_0^\zeta F(\eta, t) \exp\left(-2 \int_0^t F(\eta, \tau) d\tau\right) d\eta + \dot{z}_0(t).$$

Here $z_0 = z(0, t)$ is an arbitrary function, which can be found from an additional condition. For instance, $z_0 = 0$ if the liquid flow is symmetric about $z = 0$. We also note that z_ζ is expressed via the solutions of problems (2.2), (2.3) and (2.6), (2.7):

$$z_\zeta = 1/|\rho\sigma| \text{ for } A + \chi < 0, \quad z_\zeta = 1/|\mu|^2 \text{ for } A + \chi > 0. \quad (2.9)$$

3. Motion in a Semi-Infinite Cylinder with Singularities at the Axis of Symmetry. The problem of rotationally symmetric motion of an ideal incompressible liquid in a half-cylinder is considered in [6]. We describe the main results obtained in [6] for the problem in a semi-infinite cylinder with singularities at the axis of symmetry.

Let $\chi = \text{const}$. In this case, system (1.14) has a family of solutions $Q = -R^2F$, $B = R^2(F^2 - A)$, where $R = \text{const} > 0$; the functions F and A satisfy system (1.13). According to (1.5), for these solutions $u = -(r - R^2r^{-1})w_z/2$; therefore,

$$u = 0 \quad \text{for } r = R, t > 0. \quad (3.1)$$

This means that the cylindrical surface $r = R$ is a solid wall.

Let $F_0(\zeta)$ and $A_0(\zeta)$ be even functions. Then, the functions $F(\zeta, t)$ and $A(\zeta, t)$, which are the solution of problem (1.13), (1.15), are also even in terms of ζ . Assuming that $z_0 \equiv 0$ in (2.8), we obtain a function $w(z, t)$, which is odd in terms of z . Therefore,

$$w = 0 \quad \text{for } z = 0, t > 0. \quad (3.2)$$

Thus, the solution considered satisfies the no-slip condition at the half-cylinder base $S_R = \{(r, z): 0 < r < R, z > 0\}$.

By virtue of (1.5), (1.8), (1.15), (1.16), and (2.8), and the assumptions about the functions Q and B , the initial data for the functions u , v , and w have the following form:

$$u = (r - R^2r^{-1})F_0(z), \quad w = -2 \int_0^z F_0(\zeta) d\zeta, \quad (3.3)$$

$$v = r^{-1}\{r^4(A_0(z) + \chi) - R^2r^2(A_0(z) - F_0^2(z)) + K - R^4F_0^2(z)\}^{1/2}.$$

The requirement of non-negativity of the expression in braces for $(r, z) \in S_R$ imposes restrictions on the functions F_0 and A_0 and parameters R , χ , and K . In particular, the necessary conditions of non-negativity are $K \geq R^4F_0^2(z)$ and $K \geq -R^4\chi$; adding the condition $A_0(z) + \chi < 0$, we obtain the sufficient conditions.

The solution of problem (3.3) for system (1.4) with the initial and boundary conditions (3.1) and (3.2) describes the vortex motion of an ideal incompressible liquid in a half-cylinder bounded by solid walls. This solution depends on two arbitrary functions $F_0(z)$ and $A_0(z)$ and three constants K , χ , and R . As follows from the results of Sec. 2, for $\chi = \text{const}$, the solution of problem (1.13), (1.15) can be expressed in elementary functions. Equation (2.8) can be used to obtain a parametric representation of the functions u , v , and w in quadratures. As a result, a wide class of exact solutions of the Euler equations was obtained, which describe nonlinear interaction between vortex sources distributed at the axis of symmetry in the case of steady, rotationally symmetric motion of an ideal incompressible liquid in a half-cylinder.

Pukhnachev [6] considered an example of solving problem (1.13), (1.15) for $\chi = 1$ and the initial data F_0 and A_0 are finite functions of ζ with the support $[-1, 1]$. In the present work, we construct a solution for the case $\chi = 1$ with different initial data.

Thus, we consider the case $\chi = 1$. The functions F_0 and A_0 , which are finite functions of ζ with the support $[-\delta, \delta]$, are defined by the formula

$$F_0(\zeta) = A_0(\zeta) = \begin{cases} 1 - |\zeta|/\delta, & 0 \leq |\zeta| \leq \delta, \\ 0, & |\zeta| \geq \delta. \end{cases} \quad (3.4)$$

We consider the case $A_0 + \chi > 0$, i.e., $A_0 > -1$. By virtue of (2.5) and definitions $H = F + iG$ and $A + \chi = G^2$, we obtain

$$F = \text{Re}(\ln \mu)_t, \quad A = [\text{Im}(\ln \mu)_t]^2 - 1. \quad (3.5)$$

According to (2.6) and (2.7), the function $\mu(t, \zeta)$ has the form

$$\mu = \cos t + [F_0(\zeta) + i(A_0(\zeta) + 1)^{1/2}] \sin t. \quad (3.6)$$

The function $z(\zeta, t)$ is obtained by integration of (2.9) under the condition $z(0, t) = 0$:

$$z(\zeta, t) = \begin{cases} \int_0^\zeta \frac{d\eta}{|\mu(t, \eta)|^2} \equiv Z(\zeta, t), & 0 \leq \zeta \leq \delta, \\ \zeta - \delta + h(t), & \zeta \geq \delta. \end{cases} \quad (3.7)$$

Here $h(t) = Z(\delta, t)$ is a 2π -periodic function of time. In deriving (3.7), we assumed that $|\mu| = 1$ for $\zeta \geq \delta$, which follows from (3.6) and the equalities $F_0 = A_0 = 0$ ($\zeta \geq \delta$).

From (3.5)–(3.7), we can easily find the third component of velocity and the expression for z in a parametric form. In particular, we have $w = Z_t$ if $0 \leq \zeta \leq \delta$ and $w = \dot{h}(t)$ if $\zeta \geq \delta$. This means that the no-slip condition is satisfied on all surfaces $z = h(t) + N$, where $N = \text{const} > 0$. In addition, $u = 0$ and $v = r^{-1}(K + r^4)^{1/2}$ for $z \geq h(t)$, since $F = A = 0$ for $\zeta > \delta$. Note, the constant K should satisfy the inequality $K > R^4 F_0^2 + R^4(A_0 - F_0^2)/(4(A_0 + 1))$, which ensures the positiveness of the radicand in (1.8).

Thus, the liquid enclosed between the surfaces $z = h(t)$ and $z = h(t) + N$ moves as a rotating piston. The nontrivial motion periodic in time is located in the region $0 < r < R$, $0 < z < h(t)$. This motion is generated by interaction of vortex sources distributed over the segment $[0, h(t)]$ of the axis of symmetry. The vortex circulation is $2\pi K^{1/2} = \text{const}$, and the source power $M = -2\pi R^2 F$ is a function periodic in time.

Thus, if the initial data have the form (3.4), we obtain

$$h(t) = 2 \frac{\delta \arctan [(2\zeta \sin t - 3\delta \sin t - 2\delta \cos t)/(\delta \sqrt{3 \sin^2 t - 4 \sin t \cos t})]}{\sin t \sqrt{3 \sin^2 t - 4 \sin t \cos t}} \Big|_{\zeta=0}^{\zeta=\delta}.$$

In this case, the source power M is a function of two variables:

$$M(\zeta, t) = -2\pi R^2 \frac{F_0(\zeta)(\cos^2 t - \sin^2 t) + (F_0^2(\zeta) + A_0(\zeta)) \sin t \cos t}{(\cos t + F_0(\zeta) \sin t)^2 + (A_0(\zeta) + 1) \sin^2 t}.$$

The dependences $h(t)$ and $M(\zeta, t)$ for $\delta = 0.005$ and $R = (2\pi)^{-1/2}$ are plotted in Figs. 1 and 2.

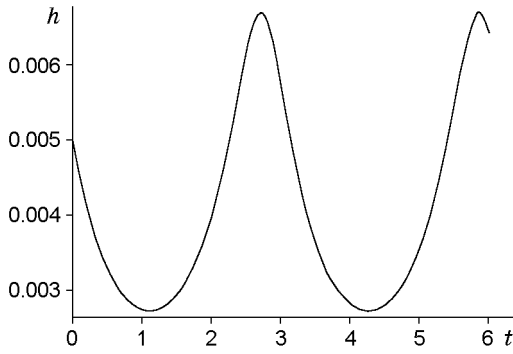

Fig. 1

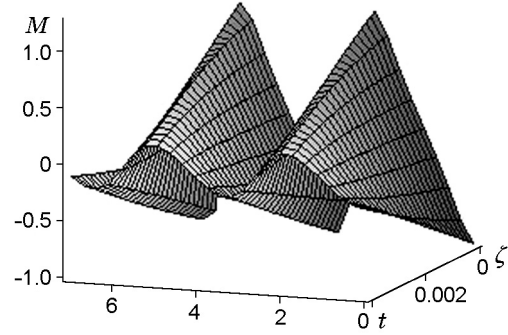

Fig. 2

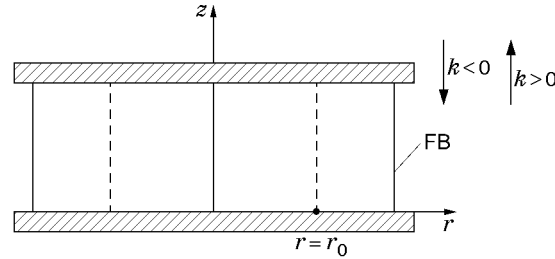

Fig. 3

4. Problem of Motion of a Liquid under a Punch. We consider the case $w = \lambda(t)z$ [the function λ is specified by formula (1.10) and $q(t)$ is an arbitrary function of time]. The function q is the intensity of sources (sinks). According to (1.5) and with allowance for $w = \lambda(t)z$, the velocity components u and w are determined by the formulas

$$u = -kr/[2(1 + kt)] + q(t)/r, \quad w = kz/(1 + kt). \quad (4.1)$$

The pressure is expressed as

$$p = -\frac{3}{8} \frac{k^2(r - r_0)^2}{(1 + kt)^2} - 3 \frac{q^2}{(r - r_0)^4} - \dot{q} \ln(r - r_0) + \int_{r_0}^r \frac{v^2(\eta, t)}{\eta} d\eta + \varkappa(t), \quad (4.2)$$

where $\varkappa(t)$ is an arbitrary function of time. Instead of the velocity component v , we introduce the circulation $\Gamma = 2\pi r v$. By virtue of (4.1) and the second equation in (1.4), the function Γ satisfies the equation

$$\frac{\partial \Gamma}{\partial t} + \left(-\frac{kr}{2(1 + kt)} + \frac{q(t)}{r} \right) \frac{\partial \Gamma}{\partial r} = 0. \quad (4.3)$$

For Eq. (4.3), we can consider an initial-boundary problem with the initial data $\Gamma(r, 0) = \delta(r)$ for $0 \leq r \leq r_*$ and boundary conditions $\Gamma(0, t) = \gamma(t)$ for $t > 0$.

Owing to scale invariance of system (1.4), without loss of generality, we may consider that the constant k other than zero equals 1 or -1 .

For Eq. (4.3), we can consider the problem of motion of a cylindrical layer under a punch (see Fig. 3, where FB is the free boundary). The lower wall of the punch is motionless, and the upper wall can move upward or downward, depending on the sign of the constant velocity k . Note, the upper wall moves upward for $k > 0$ and downward for $k < 0$.

Ovsyannikov [7] considered the problem of potential motion of a cylindrical layer under a punch; there were no singularities in the velocity field, and the velocity field was linear in terms of spatial coordinates. In the problem considered in the present work, the motion is nonpotential, and there is a vortex source at the axis of symmetry. The special feature of the problem considered is that q is an arbitrary function of time, and an initial-boundary problem can be posed for the governing equation (4.3). In addition, the velocity field is nonlinear in terms of spatial coordinates.

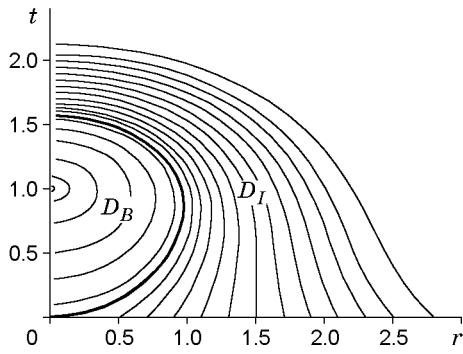

Fig. 4

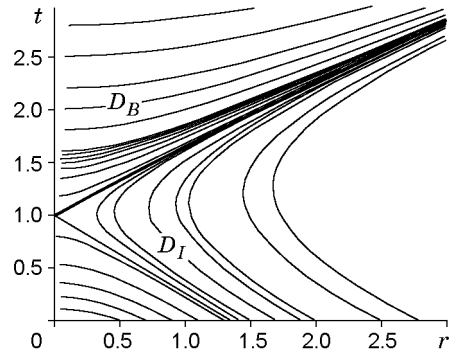

Fig. 5

The problem is considered without allowance for capillarity, since its consideration involves only one additive term $p' = p + \sigma/R(t)$, where $\sigma > 0$ is the surface tension, $r = R(t)$ is the free-surface equation, and p is prescribed by Eq. (4.2). The velocity components u , v , and w are unaffected by capillarity.

We introduce the Lagrangian coordinates. For this purpose, we consider the Cauchy problem

$$\frac{dr}{dt} = -\frac{kr}{2(1+kt)} + \frac{q}{r}, \quad \frac{dz}{dt} = \frac{kz}{1+kt}, \quad (4.4)$$

where $r = \eta$ and $z = \zeta$ for $t = 0$. Integrating system (4.4), we obtain

$$z = \zeta(1+kt), \quad r^2 = \frac{1}{1+kt} \left(\eta^2 + 2 \int_0^t (1+k\tau)q(\tau) d\tau \right). \quad (4.5)$$

Assuming that ζ and η are constants, we obtain the equations of material surfaces. The no-slip conditions for $z = 0$ and $z = z_0(1+kt)$ are satisfied automatically. Assuming that $\eta = r_0$, we obtain the material cylindrical surface determined by the second equation in (4.5). Thus, the characteristics of Eq. (4.3) have the form

$$r^2(\tau, \eta, t) = \frac{1}{1+kt} \left(\eta^2 + 2 \int_\tau^t (1+k\zeta)q(\zeta) d\zeta \right). \quad (4.6)$$

We consider the problem, where the function q has a variable sign, i.e., first a source and then a sink, and vice versa. In (4.6), we first assume that $q(t) = 1 - t^2$, and, then, $q(t) = t^2 - 1$. In this case, the equations of characteristics acquire the form

$$r^2(\tau, \eta, t) = [6\eta^2 - 3k(t^4 - \tau^4) - 4t^3 + 4\tau^3 + 6k(t^2 - \tau^2) + 12(t - \tau)]/[6(1+kt)] \quad (4.7)$$

for $q(t) = 1 - t^2$ (in what follows, this case is called “source–sink”) and

$$r^2(\tau, \eta, t) = [6\eta^2 + 3k(t^4 - \tau^4) + 4t^3 - 4\tau^3 - 6k(t^2 - \tau^2) - 12(t - \tau)]/[6(1+kt)] \quad (4.8)$$

for $q(t) = t^2 - 1$ (“sink–source”).

Obviously, for $k < 0$, the solution can exist only for a certain limited time, after which the walls collapse. Therefore, in what follows, we consider the case $k > 0$.

Assuming that $k = 1$ in (4.7) and (4.8), we obtain the characteristics $r = r_0(\tau, \eta, t)$ first for the case “source–sink” and then for the case “sink–source.”

Figures 4 and 5 show the characteristics (4.7) for the case “source–sink” and (4.8) for the case “sink–source,” respectively. The characteristics plotted by the bold lines separate the influence regions of the initial data D_I and boundary conditions D_B .

The difference in the character of singular points for the cases “source–sink” and “sink–source” should be noted. In the case “source–sink,” continuing the characteristics into the “nonphysical” half-plane $r < 0$, we can readily see that the singular point is $r = 0$, $t = 1$, which is a singularity of the center type (see Fig. 4). The initial circulation is set for $0 \leq t \leq 1$. In the case “sink–source,” this point is a singularity of the saddle type (see Fig. 5). In this case, the initial circulation can be set for $t > 1$.

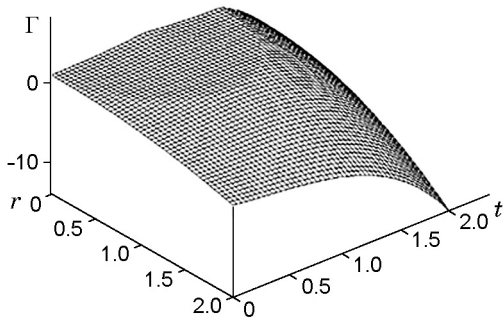

Fig. 6

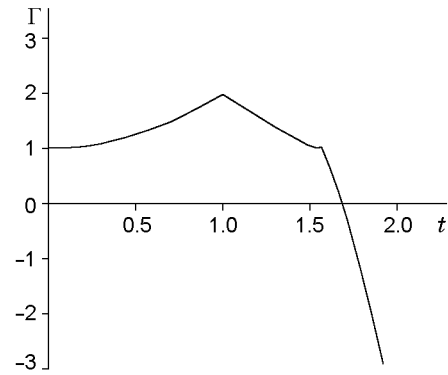

Fig. 7

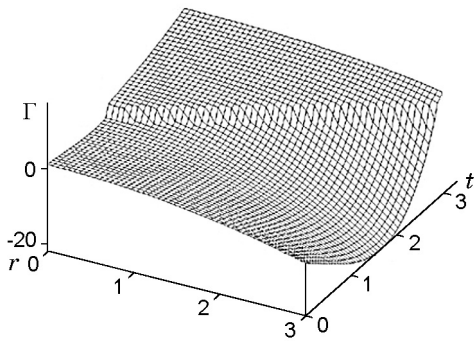

Fig. 8

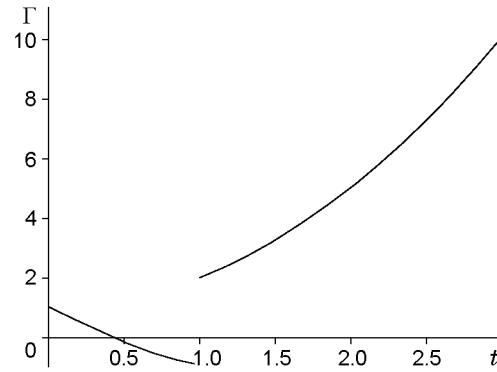

Fig. 9

We consider the case “source–sink.” Returning to the initial-boundary problem (4.3) and choosing $\delta(r) = 1 - r^2$ as the initial data and $\gamma(t) = 1 + t^2$ as the boundary conditions, we find that the function Γ in the region D_I has the form

$$\Gamma(r, t) = 1 - r^2(1 + t) - t^4/2 - 2t^3/3 + t^2 + 2t.$$

In the region D_B , the function Γ is specified by the implicit formula

$$r^2 - [-3(t^4 - (\Gamma - 1)^2) - 4t^3 + 4(\Gamma - 1)^{3/2} + 6(t^2 - \Gamma + 1) + 12(t - (\Gamma - 1)^{1/2})]/[6(1 + t)] = 0.$$

Figure 6 shows the plot of the function Γ in the region $S_1 = \{(r, t): 0 \leq r \leq 2, 0 \leq t \leq 2\}$, and Fig. 7 shows the function $\Gamma(0, t)$.

We consider the case “sink–source” with the same initial-boundary conditions $\delta(r) = 1 - r^2$ and $\gamma(t) = 1 + t^2$. As in the previous case, in the region D_I , we obtain the explicit expression

$$\Gamma(r, t) = 1 - r^2(1 + t) + t^4/2 + 2t^3/3 - t^2 - 2t,$$

and in the region D_B , we obtain the implicit expression

$$r^2 - [3(t^4 - (\Gamma - 1)^2) + 4t^3 - 4(\Gamma - 1)^{3/2} - 6(t^2 - \Gamma + 1) - 12(t - (\Gamma - 1)^{1/2})]/[6(1 + t)] = 0.$$

Figure 8 shows the plot of the function Γ in the region $S_2 = \{(r, t): 0 \leq r \leq 3, 0 \leq t \leq 3\}$; Fig. 9 shows the function $\Gamma(0, t)$. The presence of weak and strong discontinuities of the function Γ should be noted. We can easily see that the local condition of agreement of the initial and boundary conditions $\delta(0) = \gamma(0)$ is fulfilled for the case “source–sink”, and the presence of a weak discontinuity in Fig. 6 is quite natural. For the case “sink–source”, we have a strong discontinuity (see Fig. 8), which is explained by the fact that the local condition of agreement (in this case, it has a nonlocal character) is not satisfied.

We return to the physical formulation of the problem. In Fig. 3, the straight line $r = r_0$ is the boundary between the influence regions of the initial data and boundary conditions. In the plane of variables (r, t) (see Figs. 4 and 5), the curves $r = r_0(t)$ correspond to the cases $q = 1 - t^2$ and $q = t^2 - 1$. In the case “source–sink,” we can set the circulation $\Gamma(0, t) = \gamma(t)$ for $q > 0$ (i.e., when the source is acting) and $r = 0$; for $q < 0$ (which corresponds to the sink), the characteristic turns and then leaves the region S_1 . In this case, the initial circulation is not prescribed, and its value is obtained by solving the differential equation (4.3).

Thus, a new exact solution with a nonlinear field of velocities was obtained in the present work for the problem of motion of a cylindrical layer of an ideal incompressible liquid under a punch.

The author is grateful to V. V. Pukhnachev for formulation of the problems and useful discussions and to S. V. Golovin for valuable comments.

This work was supported by the Russian Foundation for Fundamental Research (Grant No. 01-01-00782).

REFERENCES

1. A. A. Buchnev, “Lie group admitted by equations of motion of an ideal incompressible liquid,” in: *Dynamics of Continuous Media* [in Russian] (collected scientific papers), No. 7, Novosibirsk (1971), pp. 212–214.
2. L. V. Ovsyannikov, “Singular vortex,” *J. Appl. Mech. Tech. Phys.*, **36**, No. 3, 360–366 (1995).
3. V. V. Pukhnachov, “An integrable model of nonstationary rotationally symmetrical motion of ideal incompressible liquid,” *Nonlinear Dyn.*, **22**, No. 1, 101–109 (2000).
4. L. V. Ovsyannikov, *Group Analysis of Differential Equations*, Academic Press, New York (1982).
5. V. K. Andreev and A. A. Rodionov, “Group classification and exact solutions of equations of planar and rotationally symmetric motion of an ideal liquid in Lagrangian coordinates,” *Differ. Uravn.*, **24**, 1577–1586 (1988).
6. V. V. Pukhnachev, “New class of exact solutions of the Euler equations,” *Dokl. Ross. Akad. Nauk*, **382**, No. 6, 777–780 (2002).
7. L. V. Ovsyannikov, “General equations and examples,” in: *Problem on Unsteady Fluid Motion with a Free Boundary* [in Russian], Nauka, Novosibirsk (1967), pp. 5–75.